

PIONEER of PINGAUGE



株式会社アイゼン

ねじ深さゲージ THREAD DEPTH GAUGE

SPD Series

ねじの深さ測定とねじ穴の^{とおり}通検査を同時に行います。

Precision measurement of internal threads and thread depths is to be done by one single instrument in one single operation

ノギス不要で「ねじ深さ」の測定、管理が出来ます。

Thread depth is to be measured and controlled without using caliper.

軽量、コンパクトな設計で、工程内での使用に最適です。

Light weight and compact design is suitable to be used in production site.

検査の作業効率を大幅に改善する事が出来ます。

Work efficiency in inspection process is to be very much improved.



ねじ穴に挿入しやすくするために、スリーブ部分に窓が付いています。

For easy insertion to internal threads, some portion on top of sleeve cut off

※最小読み取り値 1mm / 完全山を 0 として製作しています。
Minimum reading: 1mm

Zero position is fixed on starting of completed mountain portion

ねじの呼び Type of Thread	ピッチ Pitch	ゲージの種類 Type of Gauge	深さ測定範囲 Measuring Range of Thread Depth
M3	0.5	GP II / 6HGP	0 ~ 15mm
M4	0.7	GP II / 6HGP	0 ~ 15mm
M5	0.8	GP II / 6HGP	0 ~ 20mm
M6	1.0	GP II / 6HGP	0 ~ 25mm
M8	1.25	GP II / 6HGP	0 ~ 25mm
M8	1.0	GP II / 6HGP	0 ~ 25mm
M10	1.5	GP II / 6HGP	0 ~ 25mm
M10	1.25	GP II / 6HGP	0 ~ 25mm
M10	1.0	GP II / 6HGP	0 ~ 25mm
M12	1.75	GP II / 6HGP	0 ~ 30mm
M12	1.5	GP II / 6HGP	0 ~ 30mm
M12	1.25	GP II / 6HGP	0 ~ 30mm
M14	2.0	GP II / 6HGP	0 ~ 30mm
M14	1.5	GP II / 6HGP	0 ~ 30mm
M14	1.25	GP II / 6HGP	0 ~ 30mm

・オプションで止まり側ゲージをお付けする事も可能です。
No Go gauge to be added at option.

・特殊寸法も製作致します。お問い合わせください。
Special size is to be acceptable at your option.

< 使用例 >



■ 形状 Dimensions

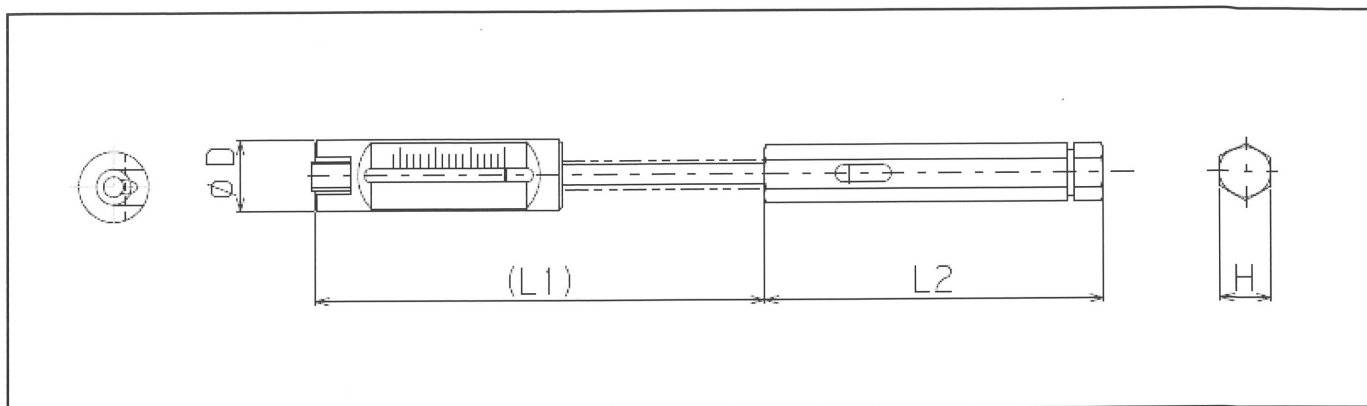

ねじの呼び Type of Thread	ピッチ Pitch	φD	L1	L2	H
M3	0.5	φ10	(60.5)	40	6
M4	0.7	φ10	(64)	48	7
M5	0.8	φ12	(76)	48	7
M6	1.0	φ12	(89)	48	7
M8	1.25	φ14	(92)	56	9
M8	1.0	φ14	(92)	56	9
M10	1.5	φ14	(92)	56	9
M10	1.25	φ14	(92)	56	9
M10	1.0	φ14	(92)	56	9
M12	1.75	φ20	(114)	63	11
M12	1.5	φ20	(114)	63	11
M12	1.25	φ20	(114)	63	11
M14	2.0	φ20	(114)	63	11
M14	1.5	φ20	(114)	63	11
M14	1.25	φ20	(114)	63	11



本社・工場 〒529-1413 滋賀県東近江市五個荘築瀬町 10-6
 TEL 0748-45-5100 (代) FAX 0748-45-5111
<https://eisen.gr.jp> ✉ pingauge@eisen.gr.jp

